

STRANDED COPPER CONDUCTOR ACCOMMODATED			BOLT SIZE	METRIC BOLT SIZE	COLOR CODE	DIE INFORMATION		MECHANICAL RATCHET						HYDRAULIC						DIELESS (# CRIMPS)	WIRE STRIP LENGTH
CODE (AWG)	NAVY	METRIC SIZE (CLASS 2)				DIE INDEX	TYPE	YIMRTC	OUR840	MD6 MD7	MD6--R2 MD7-34R	PATMD6 PAT600	Y34A Y34B Y34BH	Y35, Y39 Y750, PAT750	Y46 PAT46	Y45	Y48B	Y60BHU			
350 kcmil	350	----	1/2	M12	RED	18 324	RED DIE SET	----	----	----	W31RT (4) W31VT (4)	W31RT (4) W31VT (4)	----	U31RT (4) U29ART (4)	U31RT (4) U29ART (4)	U31RT (4) U29ART (4)	C31R (1) C29AR (1)	L31RT (1) L29ART (1)	HYDRAULIC: Y644 (1) PAT644 (1) Y81KFT - SERIES (2) Y4PC834 - SERIES (2)	2 - 1/16"	
							NEST	----	----	----	----	----	B31D (2) A31D (2) Y34PR	U31D-1 (2) Y34PR	U31D-1 (2) Y34PR	U31D-1 (2) Y34PR	C31D-1(1) Y48PR	----			
							INDENTOR	----	----	----	----	----	----	----	----	----	----	----			

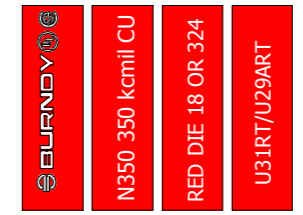

BARREL MARKING

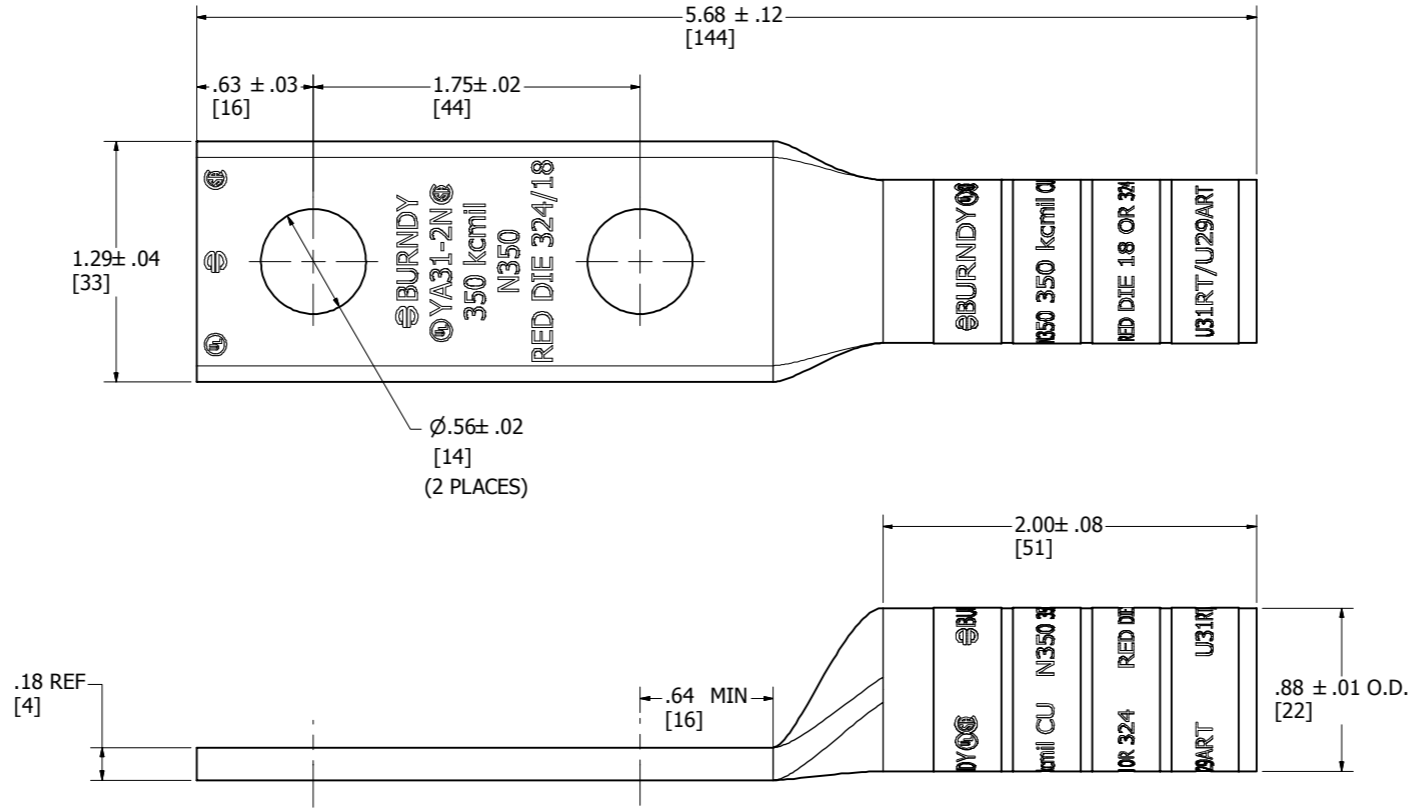
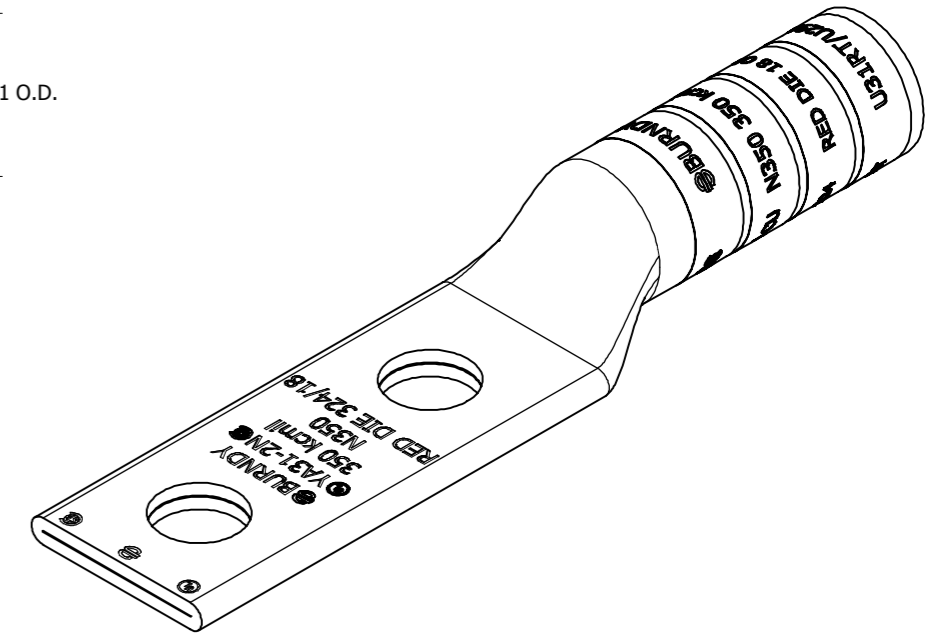

NOTES:

1. MATERIAL: COPPER TUBING
2. FINISH: TIN PLATED.
3. CATALOG # PT6515 ADAPTOR IS REQUIRED TO USE "U" DIES IN Y45 SERIES TOOLS.
4. CATALOG # PUADP-1 ADAPTOR IS REQUIRED TO USE "U" DIES IN Y46 SERIES TOOLS.
5. Y35P3 INDENTOR ADAPTOR REQUIRED FOR Y34PR INDENTOR.
6. PERMANENT DIE IN TOOLING.
7. DIMENSIONS IN BRACKETS [ ] ARE IN MILLIMETERS ROUNDED OFF TO THE NEAREST MILLIMETER, UNLESS OTHERWISE NOTED, AND ARE FOR REFERENCE ONLY.
8. FOR USE BY CUSTOMERS THAT HAVE THIS HYPRESS.™ NO NEW Y34A HYPRESS™ TOOLS ARE BEING PROCESSED. Y34A USES A--D TYPE NEST DIES.
9. UL LISTED AND CSA CERTIFIED WIRE CONNECTOR.
10. "X", "W-RT", "W-VT", "U", & "L" DIE SETS ARE COLOR CODED. "A", "B", AND "C" DIES ARE NOT COLOR CODED. NESTS AND INDENTOR TYPE ARE NOT COLOR CODED.

REV	DATE	DESCRIPTION	ECO	BY	C'H'K.
B	07/29/13	CORRECTED TONGUE STAMPING AS PER MARK UP	32639	VK	PB

HYLUG™			
ITEM NO: 502520			
CAT. NO: YA312N			
DRAWN BY: S. SRIRAM	11/27/2012		
CHECKER: J. MICHAUD	5/2/2013		
DSN APRVL: R. ROMAN	4/26/2013		
MFG APRVL: M. KNAPTON	3/18/2013		
QA APRVL: T. WATTS	3/18/2013		
MKT APRVL: J. SYLVIA	5/3/2013		
PROD FAM: CM&R COMPRESSION	DRAWING NO	REV	
PROJECT #: --	SIZE	50010006	B
DOCUMENT TYPE: SALES			
REL LEVEL: Released	D		SHEET 1 OF 1